

CASE IH
AGRICULTURE
FOR THOSE WHO DEMAND MORE

VESTRUM CVXDRIVE

100-130 HP TRACTORS



**MACHINE
OF THE YEAR 2019**



GREAT FEATURES FOR

TRANSPORT:

- 40kph at 1,600 rpm means low fuel consumption
- Suspended front axle for a comfortable ride and better traction

LOADER WORK:

- Highly durable front axle with a maximum permissible axle load of 3,700kg
- Comfortable operation via an electronic hydraulic joystick
- Tight turning radius of 4.5m for perfect agility

FIELD OPERATION

- Optimized chassis layout for a close installation of the front linkage
- Up to 7 remote valves to handle all implements
- Rear linkage with up to 5,600kg lifting power
- Fully integrated and multifunctional front end
- Headland Management Control II and ISOBUS compatibility



COMPACT AND COMFORTABLE

The Vestrum CVXDrive – as versatile as your work



THE NEW VESTRUM CVXDRIVE	04 - 05
CAB	06 - 13
ENGINE / CVXDRIVE TRANSMISSION	14 - 23
HYDRAULICS / PTO / CHASSIS	24 - 33

AFS - ADVANCED FARMING SYSTEMS	34 - 41
SERVICE	42 - 47
SUSTAINABILITY	48 - 49
SPECIFICATIONS	50 - 51

TAILOR-MADE SOLUTIONS

The new Vestrum CVXDrive

We build tractors that perform in even the toughest conditions, providing the flexibility to perform any job. Case IH machines have always followed these guiding principles, and of course the Vestrum CVXDrive is no exception!

A COMPACT PREMIUM MACHINE

The new model series, as compact as a highly-maneuvrable four-cylinder tractor, stands out from the crowd thanks to premium cab comfort and the same design as its larger sibling. And not least because it is the first Case IH tractor in the 100HP class to come with the continuously-variable CVXDrive transmission.

LISTENING TO CUSTOMERS

Compact tractors are extremely popular with mixed and medium-sized farms as genuine workhorses. That said, customers in this segment are showing increased interest in the continuously-variable technology, and the Vestrum CVXDrive is our response to their practical requirements. Given the vast range of applications performed by compact tractors, the continuously-variable drive on the Vestrum CVXDrive can give full reign to its range of high-tech features unique to this HP class. Your everyday routine has just become much easier.

CONCENTRATED TECHNOLOGY IN A COMPACT PACKAGE

Alongside the continuously-variable technology, the Vestrum CVXDrive series offers powerful yet efficient 4.5l Stage V engines, the last word in high-performance hydraulics and PTOs together with complete AFS and ISOBUS III integration.

ALWAYS THE RIGHT CHOICE

Whether high or low roof, or the new cab with low roof and panoramic high visibility window: Choose your Vestrum CVXDrive and configure your tractor to suit the unique needs of your farm.

FUEL FRUGAL AND POWERFUL

- 4-cylinder common rail engine with intercooling and Wastegate turbocharger
- 100-130HP rated power, 10HP additional power without boost
- Environmentally friendly: fulfills EU Stage V emission level
- HI-eSCR2 system with diesel oxidation catalyst (DOC) and SCR catalyst (SCRoF) compactly integrated all in one box under the bonnet
- Completely maintenance-free and multi-patented exhaust gas treatment system

HEADLAND MANAGEMENT AND ISOBUS

- Headland management I
- Extended headland management II
- ISOBUS Cl. II
- ISOBUS Cl. III (speed control)

FULLY INTEGRATED FRONT MOUNTING SYSTEM

- Front linkage with 2,300kg lift capacity
- 4 hydraulic couplers and low pressure return coupler
- Front electrics with 7- and 3-pin 40 A ISO plug socket
- 1,000rpm front-mounted PTO

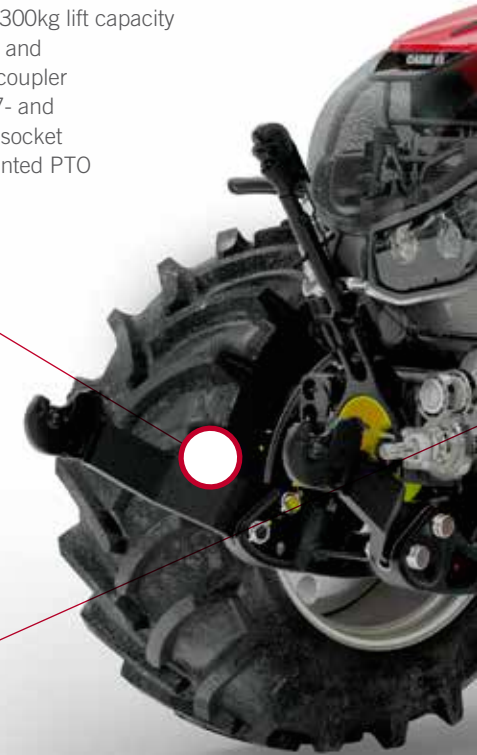

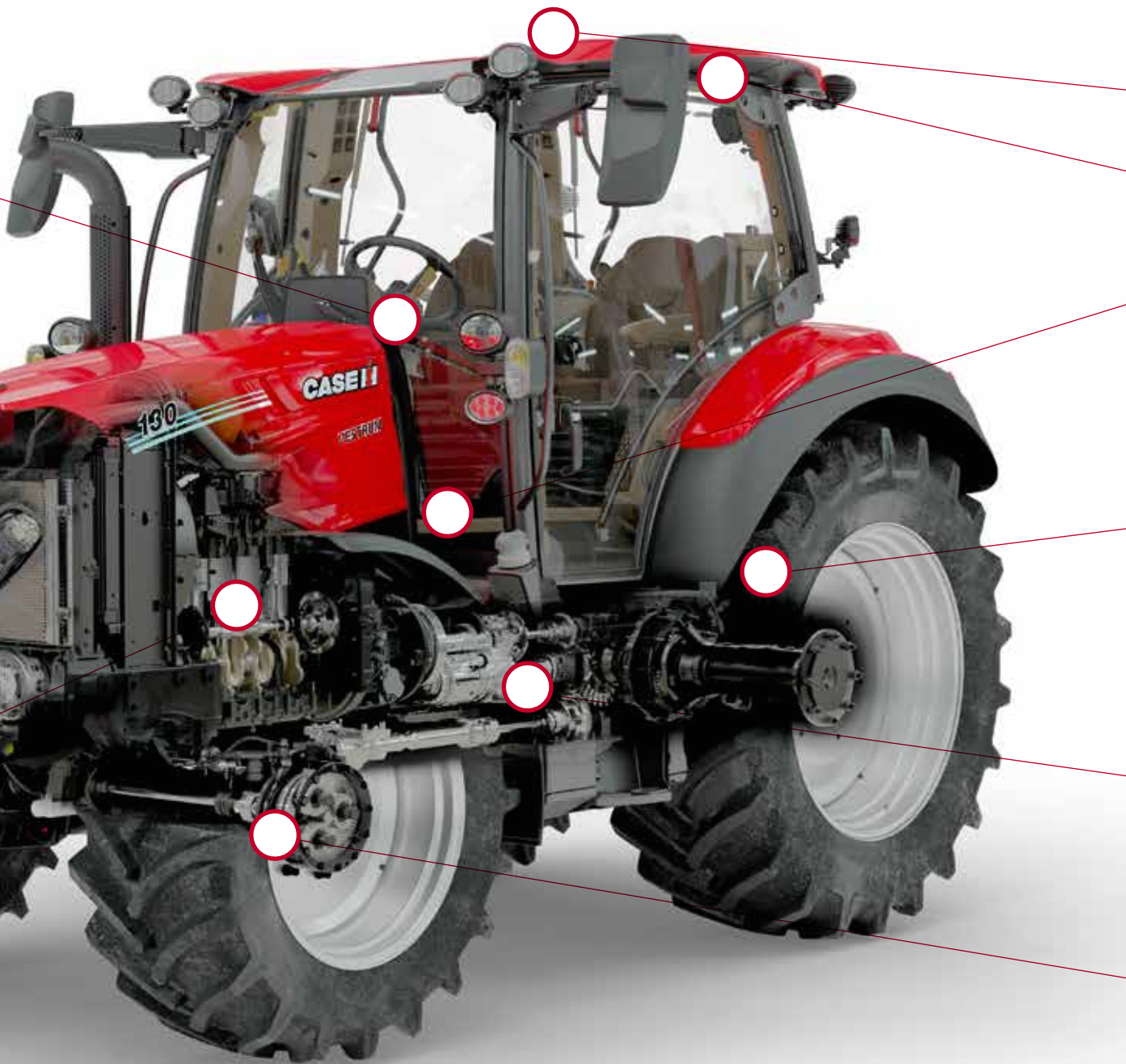

AFS ACCUGUIDE

- Satellite-controlled steering system

THREE DIFFERENT ROOF OPTIONS

- High roof with roof window
- Low roof with roof window
- Low roof with panoramic high visibility window

AIM HIGH

- Manoeuvrable thanks to 4.5m turning radius with 55° steering angle
- Optimal visibility onto front hitch courtesy of sloping bonnet
- Electronic joystick including switches for 3rd and 4th service diverters
- Loader-ready ex factory

HANDLE THE HEAVIEST JOBS

- PFC hydraulic system with 110l/min pump capacity
- 5,600kg lift capacity
- External controls for rear hitch, hydraulics and PTO
- Up to 4 remote valves at the rear
- Up to 3 mid-mount remote valves
- Power Beyond connection available as an option

STEPLESS, SEAMLESS

- Automatic Productivity Management (APM) – perfect interaction of engine and transmission
- CVXDrive transmission with 0-40kph stepless speed range
- Active hold feature for safety on slopes

SMOOTH RIDE – TIGHT TURNS

- Suspended and braked front axle options
- 8,800kg permissible total weight
- 4WD and differential lock management
- Maximum tyre size up to 600/65 R38
- Reactive steering



A CAB WITH “WOW”

Climb in and enjoy the comfort!

Excellence both outside and inside: The new Vestrum CVXDrive makes a great first impression, and it only gets better when you sit in the cab. The cab is a workplace that makes you feel good, which forms a huge part of the exceptional comfort provided in this HP class.

The user friendliness is just what you have come to expect from Case IH. The new panoramic high visibility window, optimised for front loading work, gives you a safe and clear view of your surroundings at all times.



A GENUINELY COMFORTABLE WORKPLACE

Sit back and enjoy high performance



With the Vestrum CVXDrive, Case IH brings you the premium comfort you're used to from larger models to the mid-range 4-cylinder segment. Step into a workplace that you can simply feel comfortably at home in.

PREMIUM COMFORT IS STANDARD

For the first time, Case IH allows you to choose between three different roof types, so that the tractor can be configured to meet your specific requirements. The Multicontroller armrest is a common feature of all Case IH Vestrum CVXDrive tractors. A 4-pillar cab with 5.87m² of windows meets ROPS and FOPS standards

STAY ALERT, BOTH DAY AND NIGHT

The Vestrum CVXDrive offers a five-setting, adjustable cab suspension system for safe and comfortable operation; it provides always a smooth ride for the driver during road or fieldwork. A high-power LED lighting package, with up to 18 LED work lights, enables you to work in the dark and provides complete 360° illumination without shadows.

BENEFITS

- Premium comfort in the mid-range 4-cylinder segment
- Multicontroller armrest
- Three cab versions: High roof cab, low roof cab and low roof cab with panoramic high visibility window
- Five-setting, adjustable cab suspension
- Up to 18 LED work lights available



EXTENSIVE FEATURES

Versatile enough to meet all your farm's needs

PANORAMIC ROOF VERSION IS WELL-DESIGNED DOWN TO THE SMALLEST DETAIL

A continuous front screen with 235° wiper field offers outstanding visibility. Heated front and rear windscreens are available as options for an ice-free start on those frosty mornings.

Pick yourself up on warm days with a cool drink from the chilled compartment with lid right up front.

ADDITIONAL FEATURES MAKE ALL THE DIFFERENCE

Your expectations are high, and the Vestrum CVXDrive cab doesn't let you down. All the main settings can be adjusted from the AFS Pro 700 monitor, while a Bluetooth radio with hands-free function means it's easy to make phone calls in the quiet cab. In addition, a wide variety of options like an automatic air conditioning system, electrically adjustable and heated wing mirror, and a range of air-sprung comfort seats ensure stress-free work, even during long days.

EVERYTHING IN SIGHT, EVERYTHING UNDER CONTROL.

The tractor's performance monitor has a user-friendly home in the right A-pillar. An analogue display supplies you with information on fuel levels and coolant temperature, while two digital displays show all relevant information on gears, engine, PTO and hydraulics parameters.



A generous cooler compartment gives you plenty of space for food and drinks (low roof cab with panoramic high visibility window)



THE CHOICE IS YOURS

Cab roof in three versions



STANDARD CAB ROOF

The standard high roof cab can be ordered with or without adjustable high-visibility roof. The highlight of these versions is the outstanding visibility they offer through the roof and the spacious headroom. A high-power LED lighting package is also available. This roof is 10.5 cm higher than the standard low roof.



GOOD HAS JUST GOT BETTER: NEW LOW ROOF WITH PANORAMIC HIGH VISIBILITY WINDOW

The low roof with high visibility window is an innovative solution from our Case IH engineers. The roof window blends almost seamlessly into the front windscreen, the continuous glass screen ensuring an unrestricted view onto the front loader attachments.



STANDARD LOW ROOF

The exceptionally low roof design makes this the ideal solution for working in low buildings that are unsuitable for other tractors. A manual air conditioning system can be ordered as an option with the standard low roof.



USER-FRIENDLINESS YOU'RE ACCUSTOMED TO

Coming now to the 100 HP class

MULTICONTROLLER CONTROL ARMREST

The same control layout with the Multicontroller armrest is available on Case IH tractors, from Vestrum CVXDrive to the Optum CVXDrive and Quadtrac. If you and your staff already work with Case IH models and are familiar with the controls, this can significantly boost your productivity.

EVERYTHING WITHIN REACH!

The most common functions are controlled from the ergonomically-optimised Multicontroller and the ICP control panel. Both elements are integrated into the control arm, which is also available as an electrically adjustable unit. The elements are backlit.

Using the knobs under the armrest cover, you can set a range of parameters such as flow rate and time control, and front hitch lift management.

ICP OPERATING UNIT FOR A BETTER OVERVIEW

To make sure Case IH drivers get used to operating the Vestrum CVXDrive as quickly as possible, it has been fitted with innovative control units from larger Case IH tractor series. All of the most important buttons and switches have been grouped on the arm rest for very comfortable and intuitive operation. The driver's daily work is noticeably easier, while operator errors are prevented.

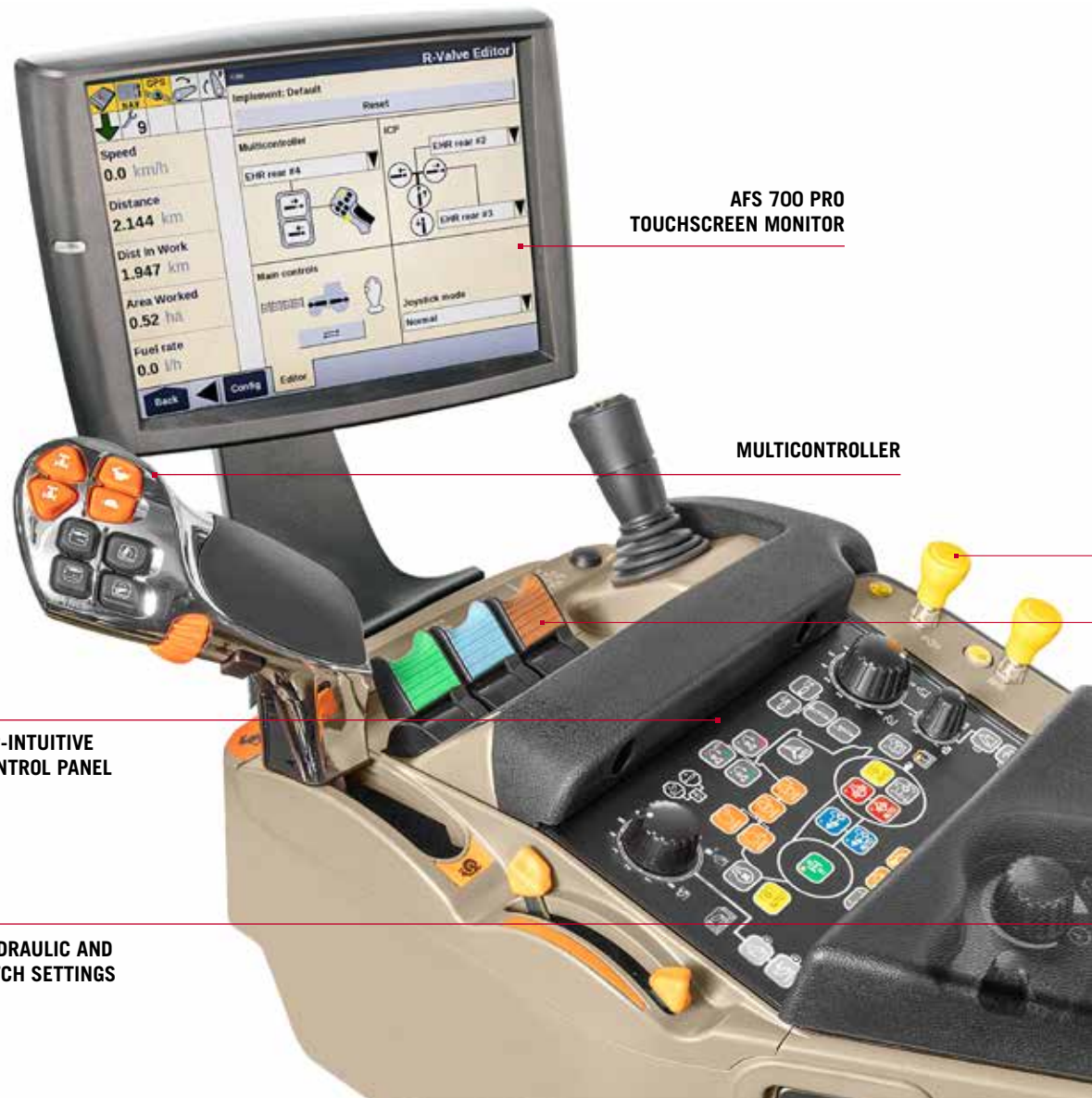

AFS 700 PRO
TOUCHSCREEN MONITOR

MULTICONTROLLER

ICP-INTUITIVE
CONTROL PANEL

HYDRAULIC AND
HITCH SETTINGS

UNPRECEDENTED VARIETY OF OPTIONS

Our watchwords at Case IH are simplicity and “at the touch of a button”

YOU'RE IN CONTROL – THE ERGONOMIC MULTICONTROLLER

The Multicontroller offers the best possible ergonomics and a wide range of functions, all at your fingertips. With the HMC II (Headland Management Control II) option, you gain a configurable button that can be used to control any front or rear remote valves from the Multicontroller.

FRONT- / REAR PTO ON / OFF

**REMOTE VALVE LEVERS
INKL. JOYSTICK**

MAKE FRONT LOADER WORK A PLEASURE WITH THE ELECTRONIC JOYSTICK

The electronic joystick is your first choice for any work involving the front loader. The third and fourth front loader functions can of course also be controlled by the joystick. To make loading more efficient, the flowrates to the mid-mounted electrical remote valves can be continuously regulated. If the front loader is not hitched, the toggle button allows you to swap between the electric rear and mid-mounted remote valves.



MULTICONTROLLER FUNCTIONS:

- Shuttle shift forward/reverse
- Speed range change
- Raise/lower rear hydraulics
- Activate Headland Management Control (HMC II)
- Setting target speed
- Programmable control unit (with HMC II)
- AUX-N functions



A red and white combine harvester is shown in a green field under a sunset sky. The harvester is in the foreground, and the field extends to the horizon. The sky is filled with soft, golden light and scattered clouds. The overall scene is peaceful and productive.

GET THE MOST OUT OF YOUR WORK DAY.

Year after year

Case IH's engineers have included only very latest technology in the development of the new Vestrum CVXDrive's future-oriented driveline solutions. Engine and transmission set a new standard in efficiency, fuel savings, and environmental compatibility.

The powerful engine, together with the innovative CVXDrive transmission guaranteed unparalleled power transmission and a superior ride quality. Thanks to the Automatic Productivity Management (APM), which guarantees perfect fusion of engine and transmission, the Vestrum CVXDrive is a model of efficiency, covering vast areas day after day.

4.5 LITRE ENGINE WITH 16 VALVES FOR BETTER GAS EXCHANGE

COMMON RAIL INJECTION AND WASTGATE TURBOCHARGER DELIVER MORE LOW-SPEED TORQUE AND BETTER ENGINE RESPONSIVENESS

600 HOURS SERVICE INTERVAL MEANS LESS TIME IN THE SERVICE BAY AND REDUCED TOTAL COST OF OWNERSHIP

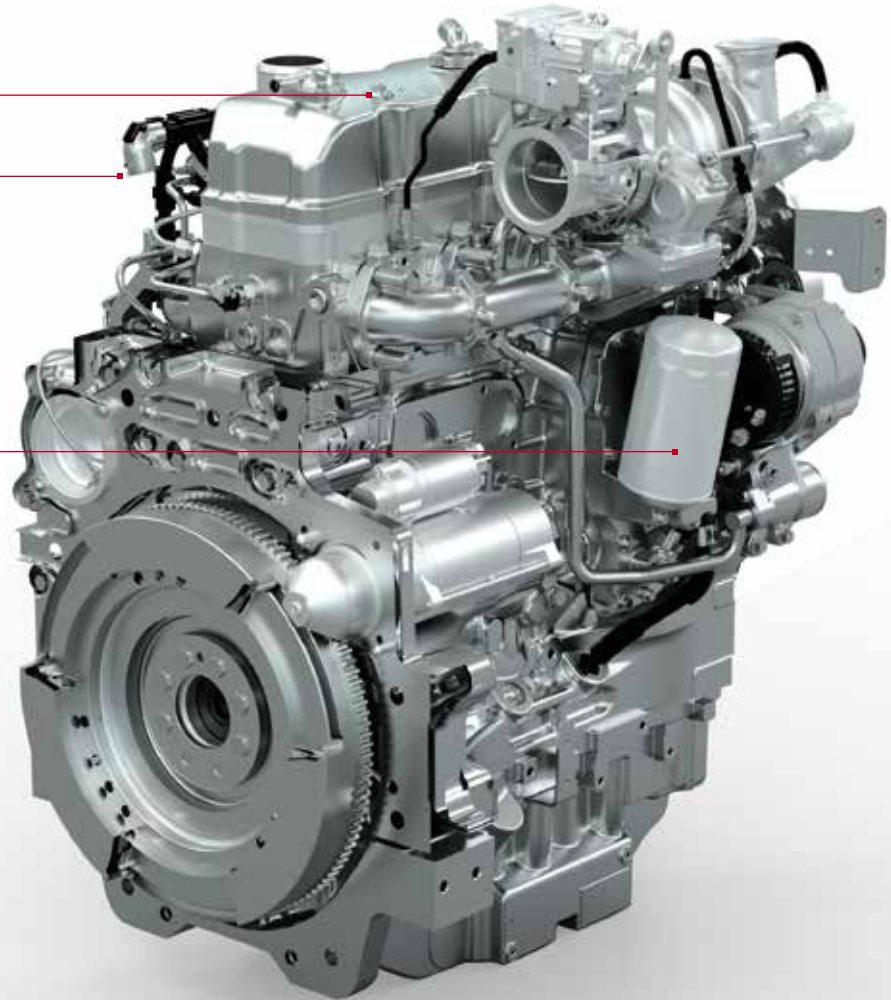

	Rated engine power hp (kW) @ 2,200rpm	Maximum engine power hp (kW) @ 1,700 – 1,900rpm
Vestrum 100 CVXDrive	100 (74)	110 (81)
Vestrum 110 CVXDrive	110 (81)	120 (88)
Vestrum 120 CVXDrive	120 (88)	130 (96)
Vestrum 130 CVXDrive	130 (96)	140 (103)

FEEL THE BENEFIT OF PROVEN EFFICIENCY

High-performance engine from FPT

Case IH once more uses proven technology from FPT on the Vestrum CVXDrive models. The innovative subsidiary enjoys an excellent reputation for its engines. The Vestrum CVXDrive engine has already demonstrated outstanding efficiency in the DLG Powermix, because it was tested in the Maxxum series.

“MR CLEAN” POWERED BY FPT

The 4.5l engine with common rail injection system and a performance range of 100 up to 130hp rated power has four valves per cylinder for optimal exhaust emissions. A modern wastegate turbocharger and downstream intercooler give the engine the peak torque typical for the “maxidyne characteristic”.

The maintenance-free HI-eSCR2 system for exhaust aftertreatment – the subject of many patents – ensures that the machine complies with the strict emissions requirements of EU Stage V.

SLIMMED DOWN FOR EFFICIENCY AND ECONOMY

The wide constant power range and the outstanding torque rise of up to 48% minimise any drop in the engine speed, and so create the perfect conditions for even the heaviest traction and PTO work.

While maximum performance is achieved at 1,900rpm, the zippy engine produces its maximum torque at a fuel-efficient 1,300rpm. This ensures fewer vibrations, pleasingly little background noise in the cab, and the ultimate in comfort for the operator.

CASE IH VESTRUM 130 CVXDrive

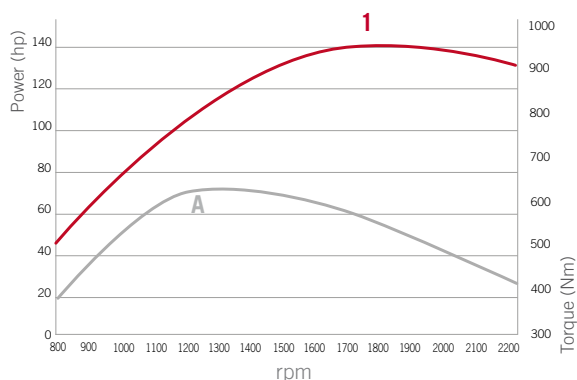

Curve 1: Maximum output of 140hp at 1,800rpm

Curve A: Maximum torque of 630Nm at 1,300rpm

EVEN MORE POWER

The Vestrum CVXDrive delivers up to 10hp extra when needed without boost, depending on the model. The max. torque is unusually high for this class.

DESIGNED FOR LONG WORKING DAYS

Long shifts in the fields can be covered without constantly having to refuel, thanks to the large tanks with capacities of 180 litres for diesel and 19 litres for AdBlue.

ADVANTAGES

- FPT engine with 100 - 130hp rating, all version meet EU stage V emissions standards
- Patented HI-eSCR2 exhaust gas treatment system
- Up to 10hp additional power from all models
- 2 constant engine speed settings
- Tanks for 180 litres of diesel and 19 litres of AdBlue
- Industry-leading 600 hour service interval



CLEAN-AIR TRACTORS – BENEFITING THE ENVIRONMENT

Our most advanced exhaust aftertreatment system

STAGE V

All Vestrum CVXDrive models meet EU Stage V emission standards, meaning that fine dust particles have been reduced by a further 40%.

PATENTED HI-ESCR2 EXHAUST AFTERTREATMENT SYSTEM

At the heart of the new system lies the multi-patented HI-eSCR2 technology from FPT, with the engineers focusing especially on effectiveness, reliability and operating safety. This innovative solution works without exhaust gas recirculation and is completely maintenance-free. All components have been integrated in a compact arrangement under the bonnet, allowing an excellent view of the front hitch and the area between the axles.

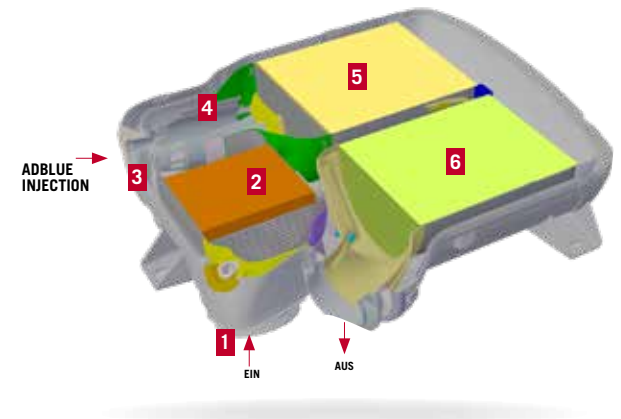

Industry-leading exhaust aftertreatment system without the need of cooled exhaust gas recirculation (EGR).

- 1** Exhaust flap: automatic exhaust gas temperature control improves the efficiency of the SCR catalyst.
- 2** Diesel Oxidation Catalyst (DOC): the DOC supports rapid heating of the SCR catalyst to operating temperature, and ensures that NO_x is reduced efficiently.
- 3** AdBlue injection system
- 4** Nitrogen oxide mixer
- 5** Selective catalytic reduction on filter
- 6** Fuel processing catalyst

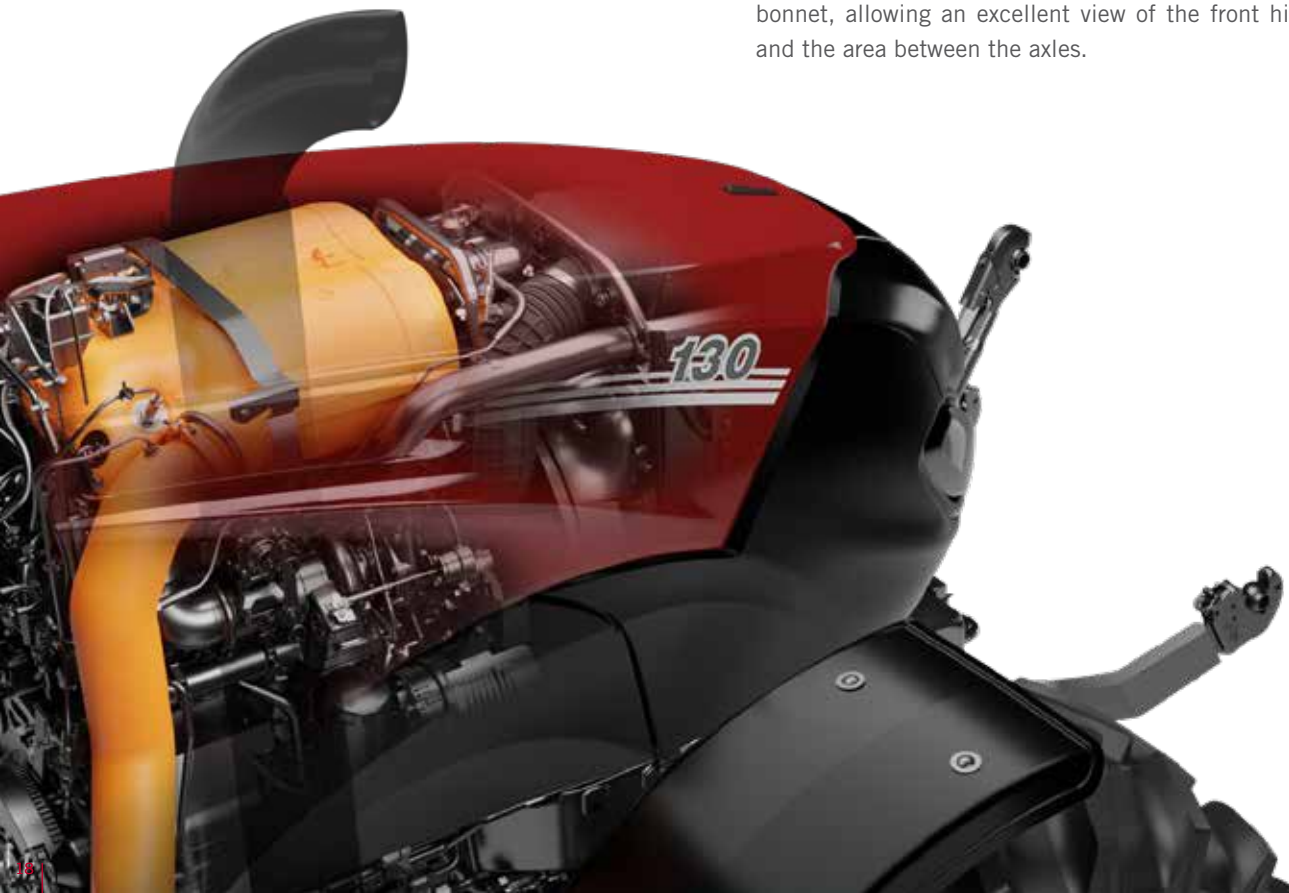

EFFECTIVE, INTELLIGENT COOLING

With Headland Management Control II in automatic mode

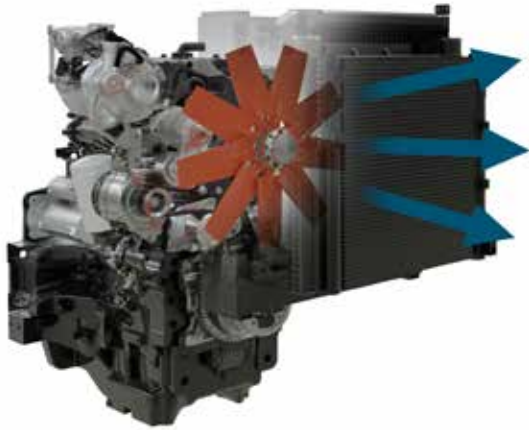

With the optional reversible fan which can be programmed as part of a headland sequence, the radiator assembly can be effectively cleaned of chaff and dirt.

PLENTY OF COOLING POWER FOR A LONG SERVICE LIFE

The standard, electronically-controlled Vistronic fan is operated by an electronic precision controller regardless of the engine speed. It only generates the cool air flow actually needed by the fan, saving fuel. The fan is fully-compatible with the optional engine brake.

MORE COMFORT, LESS MAINTENANCE WORK

For the first time in this hp class, the Vestrum CVXDrive makes use of an adjustable fan which reverses the air flow to clean the cooling unit thanks to adjustable fan blades - a unique feature within the industry.

The fan is cleaned fully-automatically if the cleaning function is set in the headland management HMC II system. This not only boosts your tractor's fuel efficiency, but saves you otherwise necessary cleaning work.

ENGINE EXHAUST BRAKE

An engine back-pressure brake is available as an option on Vestrum CVXDrive models. Generating up to 15kW of braking power, it helps reduce the use and wear of the service brake.



CONTINUOUSLY-VARIABLE TRANSMISSION, IN CASE IH STYLE

The most efficient way to work

Case IH was a pioneer of the continuously-variable drive concept, which is controlled by an intelligent engine transmission management (APM) system. For almost two decades we have worked to continuously improve this concept, now made more efficient thanks to our double-clutch technology.

USER-FRIENDLY CONTROLS

As soon as the direction is specified by the shuttle lever and the throttle or the Multicontroller is activated by the operator, the transmission will continuously accelerate from 0-40kph. The key feature here is that there is no complicated preselection process when switching between Multicontroller and throttle.

DESIGNED FOR HEAVY TRACTION WORK

The double clutch technology allows operators to engage the two mechanical forward drive ranges and a reverse gear – without disrupting the traction power and with virtually no wear.

SIMPLE DESIGN FOR A LONG SERVICE LIFE

The transmission design focuses on simplicity for maximum efficiency and reliability. At its heart lies a summing planetary transmission, which combines the drive speeds of the engine and hydro motor, guaranteeing a continuous transmission ratio from 0-40kph in the process.

SAFETY IN ALL CONDITIONS

A special feature of the Case IH CVXDrive transmission, the active hold control, ensures that the tractor does not roll on slopes without having to engage the clutch or brake. No more worries when you are working in hilly terrain, e.g. with a baler; all your attention can now be focused on baling.

An anti-jack knife function provides additional safety when pulling trailers. The transmission ratio is “frozen” by engaging the service brake, and this helps keep the combination straight.



BENEFITS

- Continuously-variable drive for maximum efficiency from 0-40kph
- Can be controlled in parallel with both foot pedal and Multicontroller
- Simple design and long service life
- Active hold control as an additional safety feature on slopes
- Automatic Productivity Management (APM) for maximum efficiency

**HYDRAULIC MOTOR + HYDRAULIC PUMP FOR
CONTINUOUSLY-VARIABLE ACCELERATION
FROM 0-40KPH**

**2 MECHANICAL DRIVE RANGES FOR ENHANCED
EFFICIENCY**

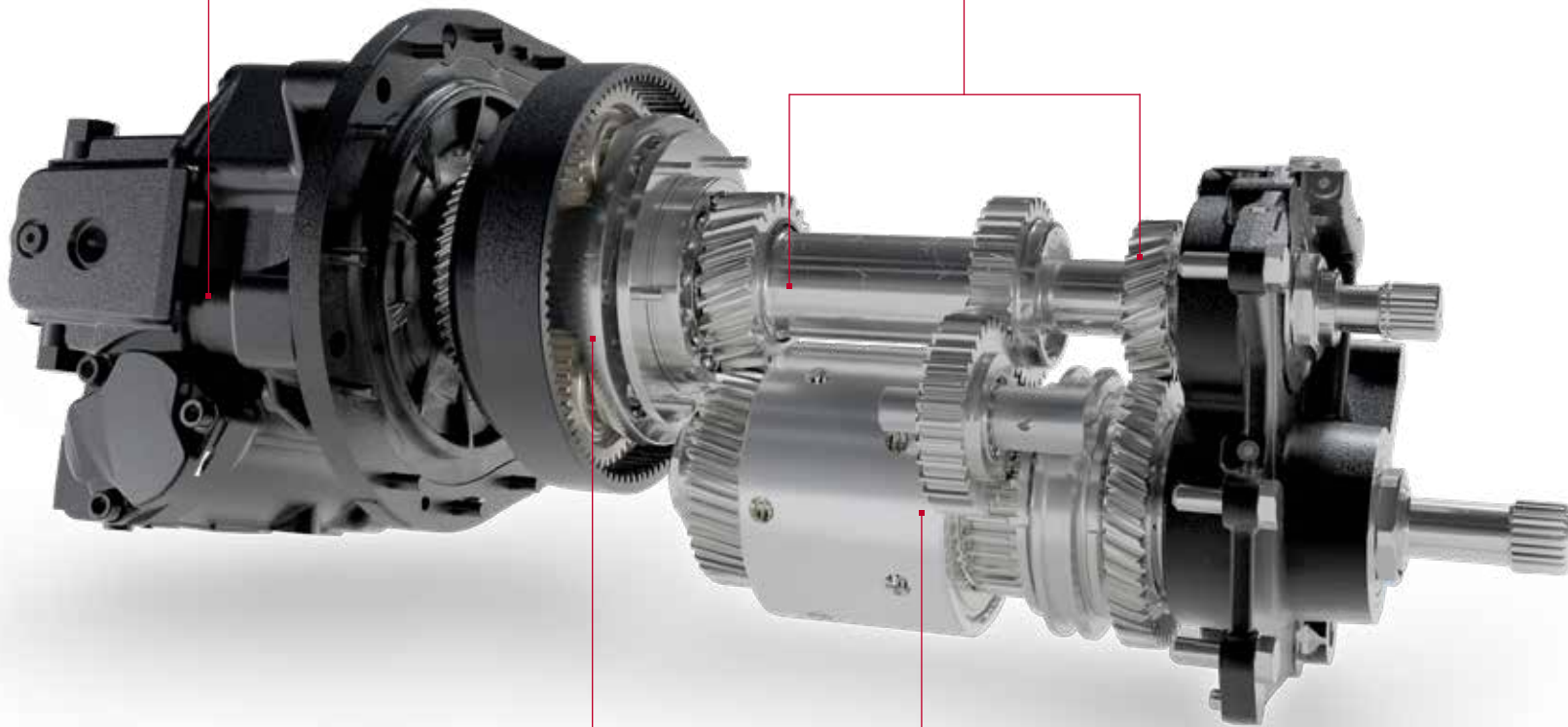

**SUMMING PLANETARY TRANSMISSION
WITH ACTIVE STATIONARY CONTROL**

**WET DUAL CLUTCH FOR GENTLE
DRIVE RANGE SHIFT**

POWER AND EFFICIENCY REDEFINED

Automatic Productivity Management (APM)



PERFECT FUSION OF FUEL EFFICIENCY AND POWER

At the start of the millennium, Case IH enjoyed great success with its revolutionary automatic productivity management system. The constant matching of engine speed and CVXDrive transmission made it possible to significantly reduce fuel consumption.

Thanks to APM, you'll always enjoy the benefit of an extremely efficient combination of speed and gear ratio, and you don't need to do a thing. A manual mode

is of course available for times when you need to work without APM.

PRECISE AND SAFE WORK

The control logic of the driving pedal has been optimised for all Vestrum CVXDrive models to allow you to adjust the handling to best match work requirements: the three sensitivity levels have got it covered!



SIMPLE TO OPERATE

Set the speed – APM takes care of the rest



The CVXDrive transmission offers three levels of aggressiveness to match the driving strategy required for the job.

CRUISE CONTROL MAINTAINS THE DESIRED OPERATING SPEED

Not unlike your car's cruise control system, the Vestrum CVXDrive models have a scroll wheel on the Multicontroller which allows operators to pre-set three speed ranges from 0-40kph, and also to switch between them quickly while at the wheel with just the touch of a button.

A MASTER OF FUEL EFFICIENCY

Get the most from every litre of fuel

ONE OF ITS STRENGTHS: TRANSPORTING WORK

To keep transport costs on the roads as low as possible, the Vestrum CVXDrive reaches its top speed of 43kph at an engine speed of just 1,720rpm. This results in reduced fuel consumption and low noise in the cab.

ECO DRIVE – SPLIT HAND THROTTLE LEVER

The split hand throttle levers has long been a valuable feature of the larger CVXDrive models and is something which Case IH operators can't live without, which is why it has now been introduced into the 100hp segment too.

With the left-hand lever, the operator sets the minimum engine speed while the right-hand lever is used to specify the maximum engine or overloading speed. These can be adjusted using the manual accelerator lever or in the AFS Pro 700 touchscreen monitor.

MODES IN DETAIL

In transport mode, the difference between the split levers should be at its maximum to allow the engine to utilise the full engine speed range. To save fuel, the maximum engine speed can be limited by moving the right-hand slider down.

In PTO mode, it's all about maintaining a specific PTO speed. If the power requirement still rises and the engine speed drops, the forward speed of the tractor is automatically decelerated to keep PTO speed at a constant level.

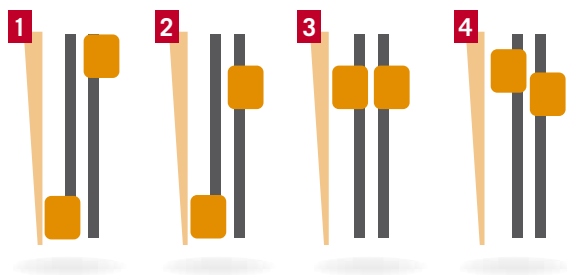

- 1 Maximum spread for utilisation of the full engine speed
- 2 The right-hand lever limits the maximum engine speed
- 3 Constant PTO speed
- 4 The left-hand lever specifies the required PTO speed, the right-hand one the lowest speed to which engine can be reduced. The transmission is controlled automatically to keep the PTO speed constant.







A VERSATILE POWERHOUSE

Efficient and versatile

The powerful hydraulics and PTOs allow the Vestrum CVXDrive to be used with the full spectrum of implements and perform to its full potential. With a solid, robust chassis, a steering angle of 55°, the high permissible total weight of 8,800kg, the low roof with panoramic high visibility window and factory-installed “loader ready” module, this tractor shows its strength even when handling difficult front loader work and in small, narrow yards.

FULL STEAM AHEAD

The hydraulic system handles even the heaviest of jobs

Regardless of whether you use heavy implements or work with other power-hungry machines: Hydraulics and implement connections on the Vestrum CVXDrive meet virtually any need, large or small.

THERE'S ALMOST NOTHING IT CAN'T LIFT

The sturdy rear linkage provides up to 5,600kg in lifting power in combination with the 110l/min PFC pump, so even heavy implements for cultivation can be used with a minimum of effort. An EHC with electronic position and traction control is as much a part of the standard package as the Active Ride Control. With the optional traction control system (Radar), the tractor automatically adjusts the EHC to the current conditions.

TIDY REAR SECTION

All rear connections like the dual-circuit braking system, trailer electrics, ISOBUS and ABS trailer control round off the neatly-designed rear of the machine. Connections are positioned to be readily accessible, which makes it easier to hitch and unhitch implements.

FULLY-INTEGRATED FRONT HITCH LIFT

The optional front linkage is integrated unobtrusively into the front axle mount and lifts up to 2,300kg. Front linkage management is available on the Vestrum CVXDrive models.

CONTROL MADE EASY

All functions used to adjust the hydraulics are located in the control armrest. Hitch lift control is easy and user-friendly using the up-down button on the Multicontroller. Front and rear hitch lifts can also be controlled from outside the cab using external operational components, whichever is more practical for your needs.

BENEFITS

- Rear linkage with up to 5,600kg lifting power
- Front linkage with 2,300kg lifting power
- Hydraulic pump with up to 110l pump capacity
- Up to 7 remote valves
- External controls for linkage and front PTO



All hydraulics can be controlled from easy to reach controllers.



External controls are provided at the front and rear of the tractor for the hydraulic life, PTO and an additional control unit.

UP TO 4 DOUBLE-ACTING
REMOTE VALVES

MAXIMUM 5,600KG
LIFTING FORCE

CAT II OR CAT IIIN
LOWER LINK HOOK

K80 BALL HEAD COUPLING

AUTOMATIC
LOWER LINK SIDE STABILISERS

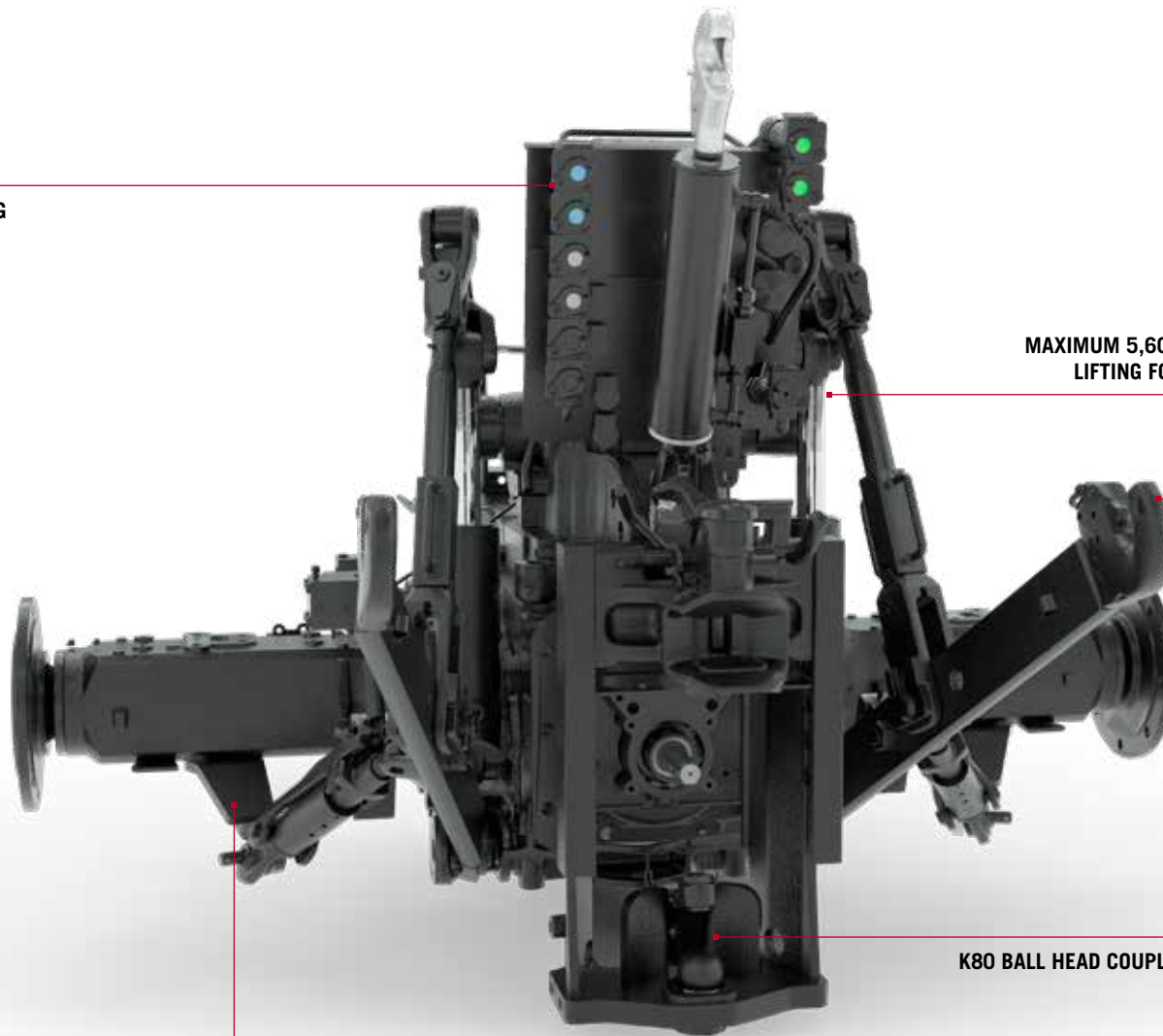

FULL HYDRAULIC POWER AS YOU NEED IT

With optional front hitch management

OUTSTANDING EFFICIENCY

All Vestrum CVXDrive models are equipped with a variable pressure and flow rate compensated high-power axial piston displacement pump. The secret of this system is that the displacement pump always supplies exactly the right amount of oil required by the hydraulics or remote valves, resulting in fuel savings for you as well as low wear.

FRONT LINKAGE MANAGEMENT

Front linkage management is available as an option for all Vestrum CVXDrive models. This feature allows the working position and maximum lifting height to be set using a dial on the armrest. The front linkage can then be easily raised and lowered to the preset positions using the Multicontroller. The automatic

float position, which is activated by lowering the front lift, together with the automatic front PTO result in unsurpassed advantages when doing jobs such as mowing or working with rollers.

REMOTE VALVES

The basic on-board equipment always consists of two mechanical rear remote valves. These can be supported by another two mechanical or electrohydraulic rear remote valves. You can fit up to three electrohydraulic mid-mounted remote valves in addition. A Power Beyond connection is also available as an option.



Models with purely mechanical rear remote valves also allow easy control via ergonomic levers.



Oil motors or implements making large demands of the hydraulics can be supplied with up to 110l of oil per minute via the Power Beyond connection.



	mechanical	electric rear remote valves	electric mid-mounted remote valves (flow rate control and timing)	Power Beyond
Standard	2	-	-	-
Optional	2	up to 2	up to 3	optional

MAXIMUM FLOW OF POWER FROM ENGINE TO PTO

Versatility is everything

WE CAN DO IT ALL

The Vestrum CVXDrive was designed with all the main jobs in and around the farm in mind, and the available PTO configurations reflect this need for flexibility. You can specify up to three rear PTO speeds for your Vestrum CVXDrive; available speeds are 540/1,000 or 540/540E/1,000 or 540E/1,000/1,000E.

Standard engine speeds are reached at 1,900rpm, and this is where the Vestrum CVXDrive performs at its peak. If less demanding work needs to be done, in other words if high torque is required instead of full engine power, you can fall back on more fuel-efficient economy PTO speeds.

EFFICIENT PTO TECHNOLOGY

PTO management disengages the PTO as soon as the hitch lift is lifted to a pre-set height, and engages it again when lowering. The same efficient and fuel-saving function in combination with front hitch lift management is also available for the front hitch lift. In

both cases, the function can be programmed using headland management HMC II.

A soft-start function is also available, which increases the pressure to the PTO clutch gradually while taking the starting resistance of the implement into account. This means that tractor and implement are protected to the same extent. The PTO brake stops the implement and prevents it from coasting as soon as the PTO is disengaged. This function can be deactivated.

EVEN MORE PRODUCTIVE

In order to enhance productivity and versatility even further, we offer a ground speed PTO for specialised applications as an extra alongside the optional 1,000rpm front PTO.



Direct power transfer from the motor to the front PTO.

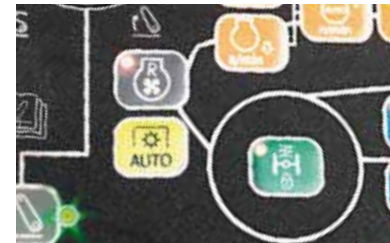

Automatic PTO mode is standard for the rear PTO and offered as an option for the front PTO.



Electro-hydraulic activation of the rear and front PTO.

**FRONT AXLE BEARING BLOCK
IS COMPATIBLE WITH
FRONT HITCH LIFT**

**DUAL PRESSURE ACCUMULATOR
FOR CONTROLLED COMPRESSION
AND REBOUNDING**

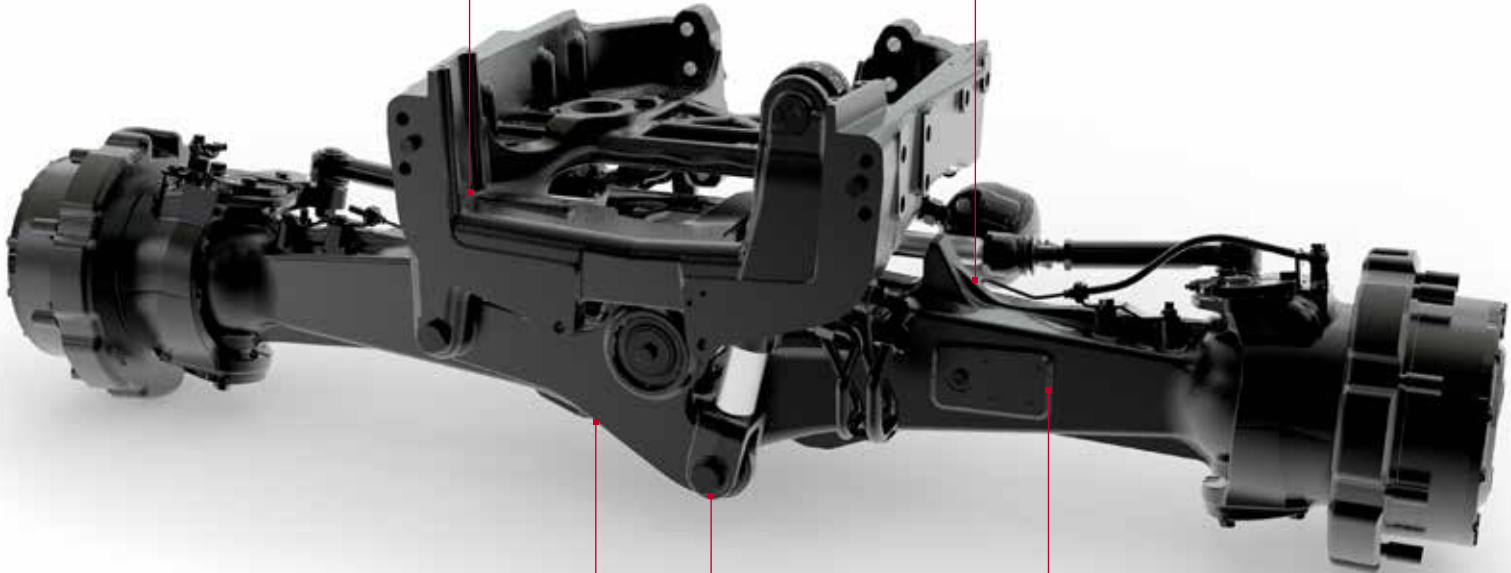

TOGGLE LEVER

**SUSPENSION CYLINDER
WITH 80 MM STROKE**

**SUSPENDED AND BRAKED AXLE CLASS
1.75 WITH STEERING ANGLE SENSOR
(OPTIONAL)**

ROBUST CHASSIS

for the ultimate in comfort and safety

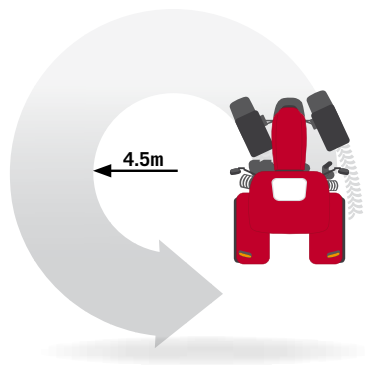

The slim shape and mobile fenders allow a turning radius of just 4.5m



Fenders that reach lower keep your tractor clean.



Easy-to-use buttons for all-wheel-drive and differential lock on the ICP control pad.

STREAMLINED MID-SECTION, SOLID BACKBONE

The front frame and axle design allows for a small turning radius with a steering angle of 55°, which makes it so much easier to manoeuvre in small, narrow yards and buildings.

Heavy-duty parts and high axle loads allow a permissible total weight of 8,800kg, making the Vestrum CVXDrive the go-to machine for arable farming and any work involving a front loader.

MOBILE EVEN IN TIGHT SPACES

Thanks to its compact design, the Vestrum CVXDrive fits perfectly into the Case IH model family. The low height of 2,835mm (2,690mm with low roof) and the total length of 3,790mm also make it the perfect companion for all yard work.

COMFORT AND SAFETY

The Vestrum CVXDrive standard front axle has a maximum load of 3.5 tons with self-locking differential. Further options include a reinforced class 1.75 axle with a maximum load of 3.7 tons in a suspended and braked version.

Hydraulically-engaged long-life brake discs enhance safety on slopes and on the roads. A choice between hydraulic and compressed air systems is also available to operators of heavy combinations.

THE RIGHT AMOUNT OF TRACTION

All Vestrum CVXDrive models offer a choice between a self-locking differential or an electrohydraulic differential lock on the front and rear axle. 4WD and differential lock management systems with their automatic functions transfer the power of the tractor to the ground via large tyres.

BENEFITS

- Tight turning circle
- Optimum power-to-weight ratio and high payload
- Braked and suspended front axle
- 4WD, Differential lock and traction management
- Maintenance free and robust long-lasting brake discs
- Easy access to the engine compartment despite its compact design

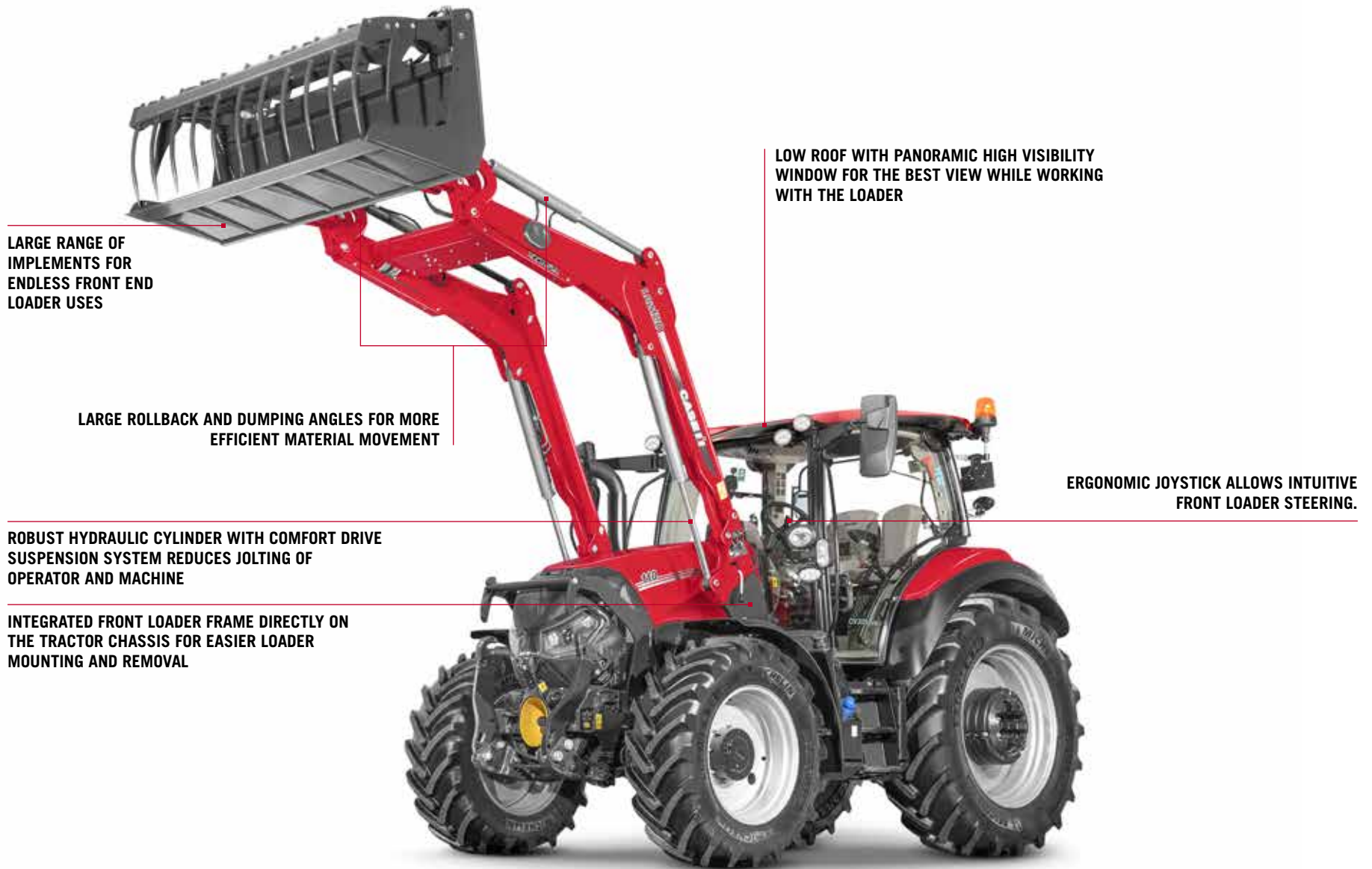

LARGE RANGE OF IMPLEMENTS FOR ENDLESS FRONT END LOADER USES

LOW ROOF WITH PANORAMIC HIGH VISIBILITY WINDOW FOR THE BEST VIEW WHILE WORKING WITH THE LOADER

LARGE ROLLBACK AND DUMPING ANGLES FOR MORE EFFICIENT MATERIAL MOVEMENT

ERGONOMIC JOYSTICK ALLOWS INTUITIVE FRONT LOADER STEERING.

ROBUST HYDRAULIC CYLINDER WITH COMFORT DRIVE SUSPENSION SYSTEM REDUCES JOLTING OF OPERATOR AND MACHINE

INTEGRATED FRONT LOADER FRAME DIRECTLY ON THE TRACTOR CHASSIS FOR EASIER LOADER MOUNTING AND REMOVAL

	LRZ series front loader			
	Max. lifting force (kg)	Max. height to bucket pivot point (mm)	Loading height with horizontal/tilted bucket edge (mm)	Recommended min/max. Tractor power (HP)
LRZ 100	2,540	3,740	3,530/2,690	70/110
LRZ 120	2,300	4,070	3,860/3,010	90/120

FLYING HIGH WITH THE LRZ FRONT LOADER MODELS

A symbiotic relationship

THREE CAB ROOF VERSIONS, ONE THING IN COMMON: CLEAR VIEW ONTO THE FRONT LOADER

Vestrum CVXDrive models not only come with the familiar standard high roof, but can also be ordered with a brand new low roof with high visibility window. The windscreen and almost seamlessly integrated roof window provide an unrestricted view of the attachments in the front loader.

THIRD HITCH FOR UNIVERSAL ATTACHMENTS

From the very start, the Vestrum CVXDrive was developed with the aim of creating the ideal machine for front loader work, which is why we can pre-fit a front loader in the assembly plant. Choose from LRZ 100 or LRZ 120 models; we can also offer a full range of buckets and implements.



USER-FRIENDLY CONTROLS

Operating the front loader is child's play with a joystick available in two versions. Using the selection key on the ICP panel, you can specify which control unit shall be actuated: rear or mid-mount remote controls.

IDEAS BORN DURING DEVELOPMENT

It's not only the outstanding manoeuvrability, but also a range of other features on the Vestrum CVXDrive which makes working with the front loader a genuine pleasure. These include electrohydraulic mid-mounted remote valves, which can be subdivided into up to 3 valve segments, two of which are earmarked for the front loader, as well as the optional class 1.75 front axle.

In addition, the 110l/min load-sensing pump, in particular, enables fast lifting and lowering speeds.



The integrated joystick can be used to control two electronic remote valves, if needed: the loader, the front linkage or the rear remote valves.

BENEFITS

- Maximum manoeuvrability and flexibility with the front loader
- Reinforced class 1.75 front axle
- Can be factory-fitted with front loader
- Choice of two LRZ front loader models
- Select from three joystick versions



LRZ front loader with mechanical parallel guidance



Slip
3%

Engine Power
91%

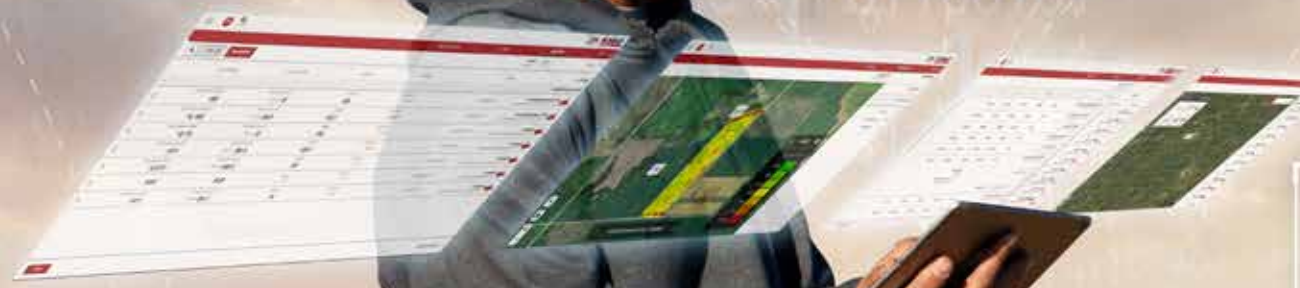

PRECISION FOR SUCCESS

Save costs and protect the environment with Case IH Advanced Farming Systems (AFS™)

A red Case IH tractor is shown in a field, with various data overlays on the screen. The overlays include: Ground Speed 6.0 km/h, Engine Power 54%, Coverage Area 26.3 ha, and Fuel Rate 89.3 l/h. The tractor is moving through a field of golden-brown crops, with a combine harvester visible in the background. The sky is clear and blue.

Ground Speed
6.0 km/h

Engine Power
54 %

Coverage Area
26.3 ha

Fuel Rate
89.3 l/h

As one of the leading agricultural manufacturers of precision farming technology, Case IH offers a range of applications that combine information input and the unique AFS Connect telematics portal into a goal-oriented data management system for registered machines. This pioneering role is underlined by value-adding features such as the latest Advanced Farming System (AFS™), full ISOBUS compability and the HMC II headland management system. Likewise, we have enabled the headland management system (HMC II) to automate more and more of the tractor's operations. With repeatable accuracy, reduced overlaps, lower operating costs, and maximisation of profits, AFS ensures both precision and success.



CASE IH AFS™

Take advantage of maximum precision - day in and day out

Case IH Advanced Farming Systems (AFS™) have been at the forefront of precision farming for more than a decade. Case IH AFS tools include everything you need to achieve repeatable accuracy down to 1.5 cm, reduce overlaps, cut operating costs and maximise your profitability.

A FULLY-INTEGRATED SOLUTION

Your Vestrum CVXDrive can be made “AFS™ AccuGuide Ready” on the assembly line with installation of the AFS Pro 700™ touchscreen and steering position sensors. You may also choose to retrofit a fully-

automatic GPS/Glonass steering assistance system. Using the signal from a local RTK+ station gives you track-to-track accuracy of 1.5 cm. The RTK system bridges breaks in reception or signal drop-outs of up to 20 minutes with the xFill app, keeping you right on track even where there is shadowing due to buildings, etc. In addition, some European markets will receive signals from Galileo satellites, in addition to GPS and GLONASS, enhancing the precision of your farm planning even more.

With the optional Case IH AFS Connect™ telematics system, your Vestrum CVXDrive can be pinpointed in real time from the comfort of your office. An analysis of the performance data can help you optimise logistics and efficiency coupled with lower fuel consumption.

OUR GOAL: OPTIMAL COVERAGE, MINIMAL FAILURE RISK

Integration of the Galileo satellite network provides a substantial boost to network coverage for our customers in Europe and further reduces the signal failure risk. If the signal is lost, the excellent coverage en-sures that it is quickly restored.



xFill bridges RTK+ signal losses of up to 20 minutes



AFS AccuGuide: GPS and Glonass based track guidance

BENEFITS

- Different signal accuracies available
- The receivers use GPS and Glonass signals
- Low-cost RTX signal
- High-precision RTK+ signal as an option with accuracy levels of up to 1.5 cm
- Integrated automatic AccuGuide track guidance system
- xFill bridges RTK signal failures of up to 20 minutes
- The AFS Connect telematics system enables geotracking and the transmission of performance data

AFS CONNECT

Manage your farm, fleet and data remotely

AFS Connect lets you remotely monitor and manage your farm, fleet and data, allowing you to optimise your performance, productivity and flexibility. Efficiently visualise your equipment with little to no idle time. With all the information at your fingertips, you can successfully manage your operations anytime, anywhere!

USER-FRIENDLY INTERFACE

- New, intuitive and redesigned interface with all information at your disposal
- Ergonomic platform divided into 3 sections: fleet, farm & data

TIME-SAVING MANAGEMENT

- Visualisation of data from multiple machines in one field
- Manage your activity & transfer data from your office to machines and vice versa

MAXIMUM PRODUCTIVITY ENHANCING DECISION MAKING

- Notifications & visualisation of critical operating parameters
- Connect and share securely with Application Programming Interface (API)

Go anywhere, see everything

RECEIVE UPDATES ON YOUR DAILY OPERATIONS

- See, share and manage data on the go, in real time, from any device
- View updated machine telematic data and fault codes remotely

THE ULTIMATE SOLUTION FOR WHEN YOU'RE ON THE MOVE.

- Live vehicle map allows lets you find machines' locations and and get driving directions
- Share vehicle info, location and directions with various apps (e.g. WhatsApp) on your phone



YOUR ALL-NEW DESTINATION FOR CASE IH PRODUCT SUPPORT

MYCASEIH is a new free cloud-based platform which gives you a single place to log in for access to everything related to your Case IH farm equipment. Find an overview of all your machine and equipment, manage your users and access a support knowledge section with operator manuals, support documents, parts catalogues and more. The platform is available on all devices: smartphone (Apple & Android), tablet and desktop.

VISIT US AT [MY.CASEIH.COM](https://my.caseih.com)



FARM MANAGEMENT

GET MORE DONE EACH DAY

Optimise your time by easily organizing your fields, applications and agronomic data

MANAGE YOUR COMPANY

Managing your fields and your data can be time-consuming. AFS Connect optimises your time by easily organising your fields, applications and agronomic data. With a wealth of information at your fingertips, you can boost your operation's performance.

- **Data visualisation:** access agronomic data in near real-time for all your seeding, application and yield activities. Included: topographic, weather, equipment, or prescriptions information.
- **Reporting:** capture all of your critical farming information on the go or directly from your equipment. Plan upcoming activities, manage logistics, share data with your trusted advisors and make informed decisions.
- **Usability:** Keeping track of everything going on in your operation has never been easier. Whether you're on the road, in the field or at the office, the intuitive user interface keeps you informed.



FLEET MANAGEMENT

TRACK, MONITOR & MANAGE YOUR ENTIRE FLEET

Efficiently track your equipment's location & view machine parameters in real time

MANAGE YOUR PRODUCTIVITY

When all your equipment operates efficiently with little to no idle time, you have the peace of mind that comes with working smarter and knowing that you're doing all you can to make the most of each growing season.

- **Fleet overview:** access key information with detailed performance values for each machine by vehicle type. The map overview allows visualisation of connected equipment to more efficiently execute in-field operations and coordinate the fleet.
- **Vehicle details page:** access recent machine operations and get a 7 day report of the vehicle status by hours and fuel usage.
- **Fault history and notifications:** view and filter the faults shown to the operator on the in-cab displays. Configure and setup notifications such as vehicle speeds, oil temperature, engine load or fuel level and receive them via web or via text messages.



DATA MANAGEMENT

CONNECT AND SHARE DATA

Securely share your farm data with trusted partners, anytime, anywhere

MANAGE YOUR DATA EXCHANGE

Seamlessly manage, share and move data — all while ensuring you stay in complete control with your preferred trusted business partners.

- **Secure data sharing:** Securely share selected data with trusted partners while keeping complete control on who can access each piece of generated data.
- **Third-party partners:** wirelessly transfer two-way data between AFS Connect and trusted third-party suppliers (AgDNA, Cropio, Farmers Edge™, Trimble® Ag Software, Climate Field View...) to make the most of agronomic data and drive daily management decisions.
- **Solutions for mixed fleets:** Case IH customers benefit from a comprehensive solution for sharing data thanks to two recent partnerships:
 - DataConnect is a new cloud-to-cloud interface, in partnership with CLAAS, 365FarmNet, John Deere and New Holland. Mixed-brand fleets owners can look forward to easier data exchange and management without compatibility issues.
 - With the universal data transfer hub Agrirouter (including many other tractor and implement brands like AGCO, SDF, Krone, Pöttinger, Lemken, Kuhn, etc., list available at <https://my-agrirouter.com/en/agrirouter/brands/>) to help ensure compatibility of tractor and implement data management systems.



MACHINE OF THE YEAR

© 2020 traction

AUTOMATED OPERATING SEQUENCES FOR INCREASED PRODUCTIVITY

Work productively, accurately, and in comfort with the headland management system, AccuTurn plus, and integrated ISOBUS compatibility

Vestrum CVXDrive operators are guided through complex operations by the comprehensive and user-friendly headland management HMC II system. All operating steps can be programmed according to time or distance covered, and triggers can be set for various automated functions such as reduction of engine speed after lifting an implement.

Headland sequences which are recorded in the field or while the tractor is stationary can then be retrieved by Multicontrollers, the AFS Pro 700™ monitor, or the

ICP control panel in the armrest, either automatically or manually as required.

ISOBUS III FOR BEST EFFICIENCY

In addition to the ISOBUS I and II standards, which suggest implement settings via the AFS Pro 700 monitor (Class I) and control implements (Class II), the Vestrum CVXDrive also offers ISOBUS class III. In the latter case, the implements control the tractor, automatically specifying the forward speed, the hitch

lift position and PTO speed, and activate the relevant auxiliary remote valves. ISOBUS III therefore delivers improved efficiency to both implement and tractor.

AUTOMATED TURNING PROCESS

The new AFS AccuTurn Pro technology also coordinates headland management and steering processes. Turning radius, speed, and implement control when turning on headlands are automated and optimised, resulting in increased efficiency and improved comfort.



Fully-automatic headland turns with AFS AccuTurn

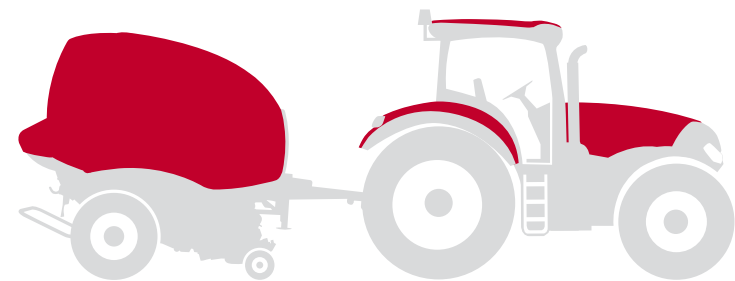

PRESS CONTROLLER

Round baler loading control algorithm (software)

ISOBUS CLASS III



TRACTOR CONTROLLER

Speed adjustments made based on relevant signals from the baler

EVERYTHING IS AT YOUR FINGERTIPS

including a wide range of intuitive functions

THE DIRECT PATH TO HIGHER PRODUCTIVITY

A shortcut menu can be configured to give you quick, direct access to any screen, allowing you to leverage the full potential of the AFS 700 monitor. Forget navigating through complicated submenus - get to your most important settings at the push of a button.

The monitor integrated into the operator's seat armrest gives the operator full control over all the tractor's automatic functions. The system also provides feedback on operating costs and the relevant yield in real time.



Freely programmable short cut menus for quick access

Its user-friendly AFS Pro 700™ software is easy to set up and allows you to communicate with the AFS automatic steering systems, as well as synchronising the tractor with ISOBUS-compatible implements.

ONE DISPLAY, COUNTLESS OPTIONS

Flow rates can be just as easily programmed via the AFS Pro 700™ touchscreen monitor as the hydraulics timing; the same applies to storing operating steps in the headland management system and connecting the reversing camera. AFS track guidance and the implement screens, which are automatically displayed

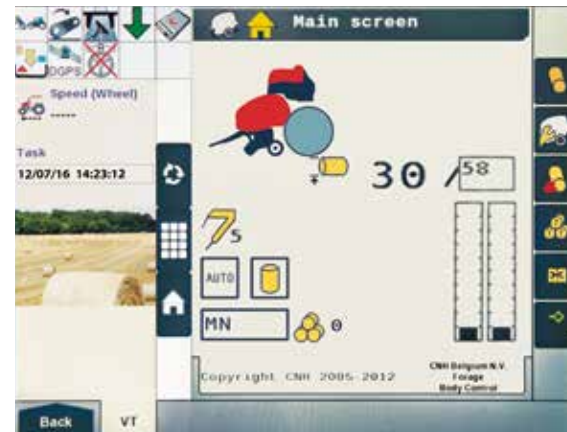

Keep blind spots in view from the driver's seat with optional additional cameras.

as soon as ISOBUS-compatible machines are connected to the front or rear, are two of the main monitor functions that can be used when working in the fields.

Coupled with the time and distance-based functions provided by headland management, you have total control over your machines. What's more, you can keep an eye on productivity and fuel consumption data, and transfer it to your office PC or a USB stick.



ISOBUS functions can be configured onto existing controllers such as the Multicontroller, joystick and control levers.



130



BE A FARMER

We take care of the rest

For Case IH customers, good service comes in a comprehensive, carefree package, which supports you every time, whatever the problem. We put everything into making sure that you have a reliable partner at your side after purchasing a new machine, and that you enjoy the best possible service. With our 24/7 supply of genuine Case IH spare parts, our round the clock MaxService, and tailored Safeguard service packages, the sky's the limit when it comes to extended warranties, services, telematics services, or insurance. Ask our experts about how we can tailor these services and CNH Capital finance solutions to meet your needs.



KEEP FARMING

Servicing made simple

We know only too well that time is always an issue in farming. The less time spent on maintenance work, the better.

Daily checks and routine maintenance on Case IH Vestrum CVXDrive series tractors can be done quickly and with a minimum of fuss. All that's needed is to perform your standard checks, and your Vestrum CVXDrive is ready to go.



We have incorporated longer 600 hours maintenance intervals into the Vestrum CVXDrive tractor design, to keep your maintenance costs down and to allow you to concentrate on what is really important.



BENEFITS

- Unrivalled 600 hour engine maintenance intervals, and 1,200 hours for transmission and hydraulics
- No particle filter maintenance required, thanks to the highly-efficient HI-eSCR2 exhaust aftertreatment
- Easy access for quick daily routine maintenance
- 180 litre fuel tank and 19 litre AdBlue tank – the largest capacities in the industry today – for very long working days

OUR SERVICE TEAM

Be a farmer. We take care of the rest

The Case IH **SERVICETEAM**, an extensive dealer network, support by local Case IH staff, market-leading Case IH companion tools, leading-edge training methods, first-class spare parts service, and exceptional logistics: just to name a few of the same we guarantee our Case IH customers excellent all-round aftersales service, so that they can concentrate on farming!

GENUINEPARTS

WE'LL KEEP YOUR MACHINES UP TO DATE

Your local Case IH sales agent, our specialist staff, the 24/7 spare parts supply team, and their colleagues in the shipping department, all form part of the Case IH service team network. They are fully trained, offer expert tips and solve problems, as they make sure that the right Case IH genuine spare parts are sourced and shipped right away to be with you next day or even sooner. This helps keep your machines in tip-top shape.



MAXSERVICE

ANY TIME, ANY PLACE

Even if you have to work around the clock, MaxService will never leave you stranded. A special hotline lets you reach the Case IH service team 24/7. Qualified staff at your dealership will be happy to help you with any technical queries, software solutions, and to order genuine spare parts. During the harvesting season, we provide a breakdown service to ensure that you can carry on working.



THE BEST FINANCE SOLUTIONS FOR ANY INVESTMENT

CNH Industrial Capital is the Case IH finance provider. Our staff are finance experts with many years of experience in farming. Not only are we familiar with the market and Case IH products, but we also understand the individual needs of your farm. This is why we can always create new finance solutions for new investments which are specially tailored to your operating requirements, because our ultimate goal is to increase your return on investment!



SUSTAINABILITY

It's a part of everything we do



REDUCE CONSUMPTION OF FOSSIL FUELS BY SWITCHING TO A **RENEWABLE ENERGY SYSTEM**



INCREASE FARM PRODUCTIVITY TO IMPROVE **FOOD SECURITY**



REDUCE **ENVIRONMENTAL IMPACT** AND OPTIMISE **ENERGY CONSUMPTION** IN ALL COMPANY PROCESSES



MORE OPPORTUNITIES TO EXCHANGE **IDEAS** AND **BEST PRACTICE** WITH ALL **INTEREST GROUPS**

Case IH is part of CNH Industrial, one of the leading capital goods companies worldwide. The company takes its environmental responsibilities extremely seriously and has been an industry leader on the Dow Jones Sustainability Index for the past nine years.

The CNH Industrial Group

- recycles 91% of waste
- recycles 27.5% of its water
- generates 56% of its electricity from renewable sources.

We bear a huge responsibility as one of the leading suppliers of capital goods worldwide. This means that we must take responsibility for all our global activities. Our responsibilities do not end at the factory gate. We have made great efforts to address global sustainability issues.

Over the years, we have increasingly focused our research and development work on safety and environmental protection to

constantly improve the standards of our products. Instead of leaving customers with a stark choice between low operating costs and ecological efficiency, our strategy aims to offer products that do both.

Thanks to innovative products and solutions which are environmentally compatible, Case IH makes a valuable contribution towards tackling global problems such as climate change. Companies today face complex and intertwined challenges, which require them to constantly evolve their approach to sustainability. Case IH believes that these challenges are key drivers in creating added value for all interest groups, i.e. the core objective of our brand.

Engineers at Case IH have made it their mission to manufacture machines which not only work on the land, but also with the land.

THE DRIVERS OF SUSTAINABILITY INCLUDE:

- The need to feed a growing population
- Protection of the soil for future generations
- Providing solutions for sustainable agriculture
- Increased public awareness
- Supporting greater public involvement



MODELS	VESTRUM 100 CVXDrive	VESTRUM 110 CVXDrive	VESTRUM 120 CVXDrive	VESTRUM 130 CVXDrive
ENGINE				
Number of cylinders / Capacity (cm ³)	4 / 4,485			
Type / Emission level	Common Rail Diesel engine, turbocharger and Hi-eSCR2 only exhaust after treatment / EU Stage V			
Maximum power ECE R120 ¹⁾ (kW/HP(CV))	81 / 110	88 / 120	96 / 130	103 / 140
... at engine speed (rpm)	1,700 - 1,900			
Rated power ECE R120 ¹⁾ (kW/HP(CV))	74 / 100	81 / 110	88 / 120	96 / 130
... at engine speed (rpm)	2,200			
Maximum torque (Nm @ 1,300rpm)	520	551	610	630
Fuel tank, diesel / urea (litres)	180 / 19			
TRANSMISSION				
CVXDrive - continuously variable transmission 40kph ECO	•			
Rear axle diff-lock type	Multi disc wet plate with management system			
Service brake	Hydraulically operated multiple wet disc brake, self adjusting			
POWER TAKE OFF				
Type	Shiftable with progressive electrohydraulic engagement. Auto PTO optional			
Speeds Standard (Option)	540 / 540E / 1,000 (540E / 1,000 / 1,000E or 540 / 1,000), all with optional ground drive			
... at engine speeds Standard (Option) (rpm)	1,969 / 1,546 / 1,893 (1,546 / 1,893 / 1,621 or 1,938 / 1,926)			
Shaft type Standard (Option)	1 3/8" 21 splines (1 3/8" 6 splines)			
FRONT PTO AND FRONT HITCH				
Front PTO 1,000 speed @ 1,920rpm	◦			
Front hitch max. lift capacity (kg)	2,300			
FOUR-WHEEL DRIVE AND STEERING (DRIVELINE)				
Type	Electrohydraulic with management system, differential lock as standard			
Front axle suspension	◦			
Min. turning radius ³⁾ track setting 1,830mm (m)	4.5			
HYDRAULIC SYSTEM				
System type	Variable displacement, pressure flow compensated pump			
Max. pump flow rate / System pressure (l/min / bar)	110 / 200			
Control type	Electronic Hitch Control (EHC) with cushion ride control			
Max. lift capacity / OECD lift capacity through range @ 610mm (kg)	5,600 / 4,200			
Max. number of rear remote valves / mid mount valves with electronic joystick	4, of which 2 mechanical are standard plus 1 or 2 mechanical or 1 or 2 electrical, power beyond / 3 electrical			
Category type	Cat II / III N			

MODELS	VESTRUM 100 CVXDrive	VESTRUM 110 CVXDrive	VESTRUM 120 CVXDrive	VESTRUM 130 CVXDrive
STANDARD TYRES ²⁾				
Front			440/65 R28	
Rear			540/65 R38	
WEIGHT AND DIMENSIONS ³⁾				
Approximate shipping weight / Permissible total weight (kg)			5,500 / 8,800	
A: Max. length from front link to rear link (mm)			4,784	
B: Total height (standard roof / low roof / low roof with panoramic high visibility window) (mm)			2,835 / 2,690 / 2,715	
C: Total width across rear fenders with extension (mm)			2,228	
D: Wheel base standard (mm)			2,490	
E: Height at centre of rear axle (standard roof / low roof / low roof with panoramic high visibility window) (mm)			2,100 / 1,955 / 1,980	
F: Track setting front / rear (mm)			1,446 - 2,154 / 1,530 - 2,154	

¹⁾ ECE R120 correspond to ISO 14396 and 97/68/EC ²⁾ other tyres on request ³⁾ With 320/85 R24 front tyres, 460/85 R30 rear tyres and track setting front 1,752mm / rear 1,630mm
 ● Standard Equipment ● Optional Equipment

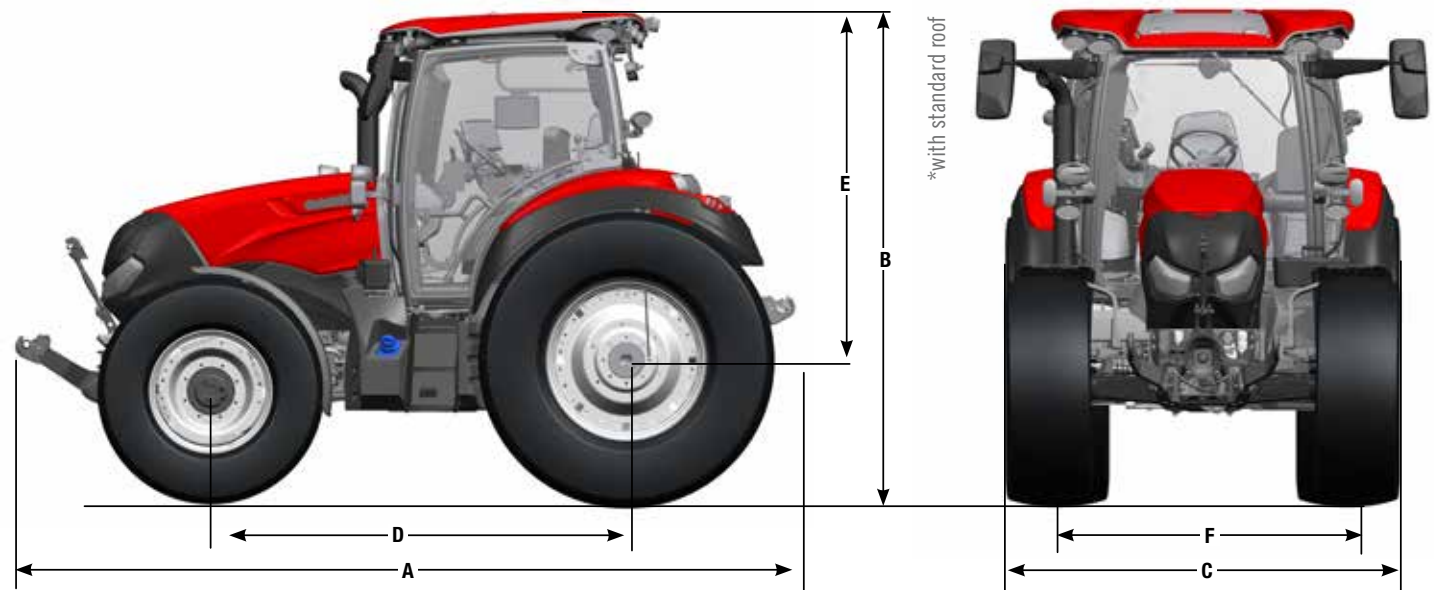

CASE IH Vestrum CVXDrive brochure – 11/2019
Cod. 19C0002COMINB
Printed in AUSTRIA

WWW.CASEIH.COM

CNH Industrial Österreich GmbH
Steyrer Straße 32, A-4300 St. Valentin – Austria

Freephone: 00 800 22 73 44 00

 Safety never hurts! Always read the Operator's Manual before working with any equipment. Inspect equipment before using it, and be sure it is operating properly. Follow the product safety signs, and use any safety features provided. This literature has been published for worldwide circulation. The standard and optional equipment and the availability of individual models may vary from one country to the next. Case IH reserves the right to undertake modifications without prior notice to the design and technical equipment at all times without this resulting in any obligation whatsoever to make such modifications to units already sold. Whilst every effort is made to ensure that the specifications, descriptions and illustrations in this brochure are correct at the time of going to press, these are also subject to change without prior notice. Illustrations may show optional equipment or may not show all standard equipment. Case IH recommends **AKCELA** lubricants.



CASE IH
AGRICULTURE
FOR THOSE WHO DEMAND MORE